

SynQor[®]

Advancing the Power Curve[®]



AC-DC Power Supplies & DC-DC Converters *Medical*



Products for the
Global Medical Environment



ACuQor[®]

CFQor[™]



Medical Grade, Highly Efficient AC-DC Power Supplies with PFC

Product Features

GENERAL SPECIFICATIONS

- High efficiency up to 93% at full rated load current
- Delivers up to 1400W of output power (1800W transient)
- Semi-regulated output — G-Series & E-Series
- Universal 85-264V AC Input Voltage (47-63Hz)
- Single output voltages: 12V, 15V, 24V, 28V, 36V, 48V
- 5V "Always On" standby power output
- Active PFC; EN61000-3-2 compliant
- Low leakage; EN60601-1 compliant
- Low noise; EN55011 / EN55022 Class B compliant
- Operating ambient temperature 0-70°C

PROTECTION/CONTROL

- Over-current, over-voltage, and over-temp protection
- DC Power Good and AC Power Good signals
- Remote enable input

SAFETY

- Type B, BF, CF & Defibrillator proof variants available
- UL 60601-1:2003
- Can/CSA-C22.2 No. 60601-1-08
- Can/CSA-C22.2 No. 60601-1-M90
- EN 60601-1:2006
- EN 60601-1/A2:1995
- IEC 60601-1:2005
- IEC 60601-1/A2:1995
- ANSI/AAMI ES60601-1:2005
- EN55011, 55022 and 61000
- CE Marked



G-Series



E-Series



Output Voltage	Power Rating		
G-Series (Single Output) (4.75" x 7.00" x 1.63" Encased Package) 12V, 15V, 24V, 28V, 48V (includes 5V@50mA standby)	800W (1000W Transient)	1100W (1300W Transient)	1400W (1800W Transient)
E-Series (Single Output) (3.00" x 5.00" x 1.46" Open Frame Package) (3.50" x 5.25" x 1.63" Encased Package) 12V, 24V, 36V or 48V (includes 5V@50mA standby)	300W (400W Transient)	400W (500W Transient)	500W (700W Transient)
E-Series (Triple Output) (3.00" x 5.00" x 1.46" Open Frame Package) (3.50" x 5.25" x 1.63" Encased Package) 12V, 24V, 36V or 48V (includes 5V@2A and 12V@4.2A)	300W (400W Transient)	400W (500W Transient)	500W (700W Transient)

E-Series



C O N F I G U R A T I O N S

E-Series ACuQor products are available open framed or encased. They can also be double or triple stacked for additional power output or multiple output voltages.*



E-Series Encased converter

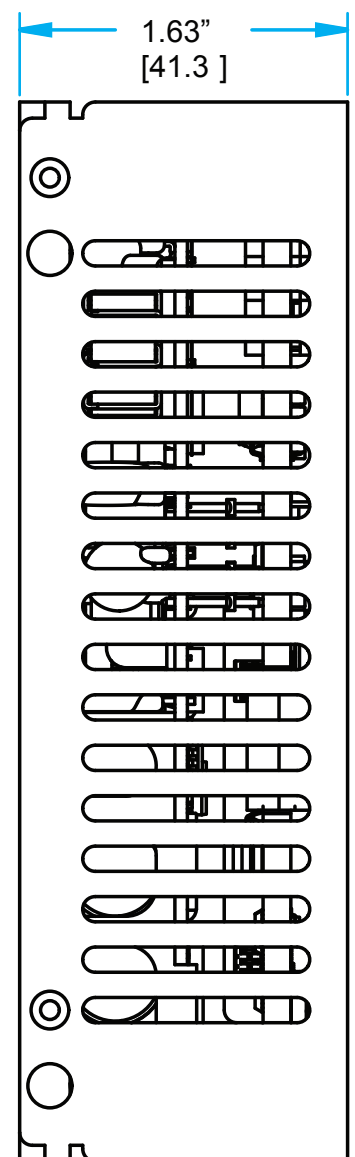
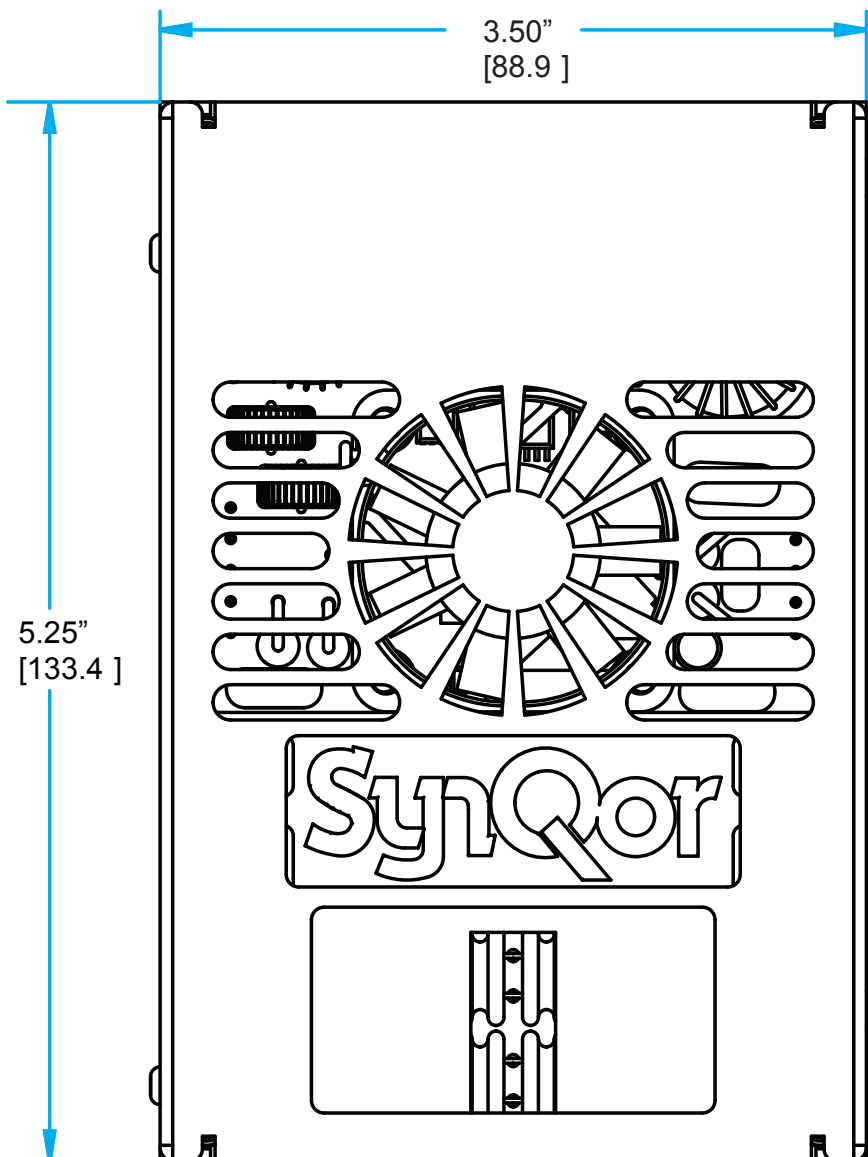

**Accessories including input and output cables are also available for all models and series.*

Mix and match a combination of 2 or 3 of any of the E-Series (3" x 5") packages in either flat or stacked packages to achieve a higher power and multiple outputs.

Double/Triple Stacked

- Double Package: S, Thermal Design: C
- Small size: 3.5" x 5.25" x 3.25"
- 600W/800W
@ 12V, 24V, 36V or 48V
- Triple Package: U, Thermal Design: C
- Small size: 3.5" x 5.25" x 4.875"
- 900W/1200W
@ 12V, 24V, 36V or 48V



Double/Triple Flat

- Double Package: R, Thermal Design: C
- Small size: 6.75" x 5.25" x 1.625"
- 600W/800W/1000W
@ 12V, 24V, 36V or 48V
- Triple Package: T, Thermal Design: C
- Small size: 10" x 5.25" x 1.625"
- 900W/1200W/1500W
@ 12V, 24V, 36V or 48V

E-Series Open frame converter

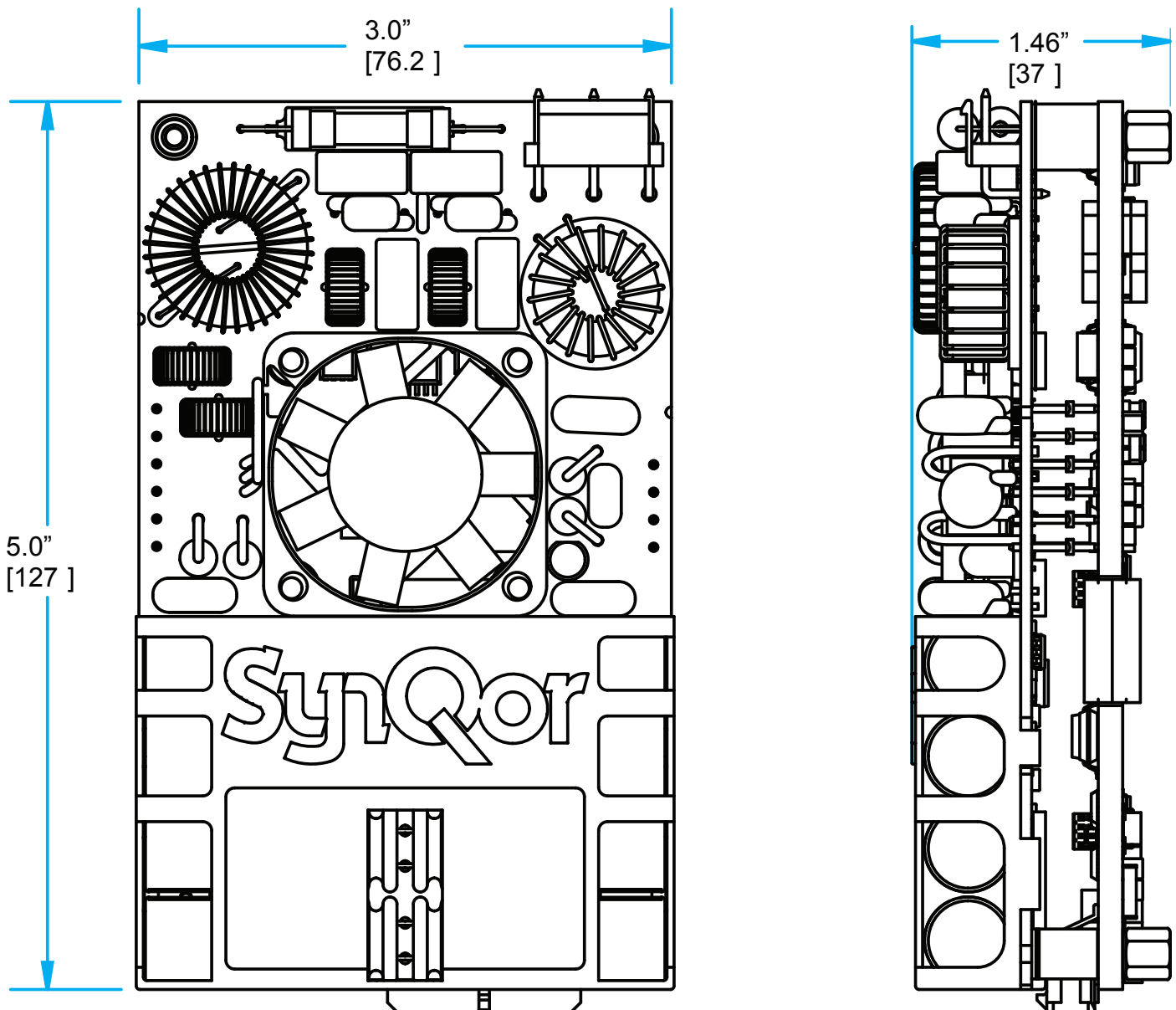

G-Series

P A C K A G E

G-Series ACuQor products are available as encased product only. *



G-Series converter

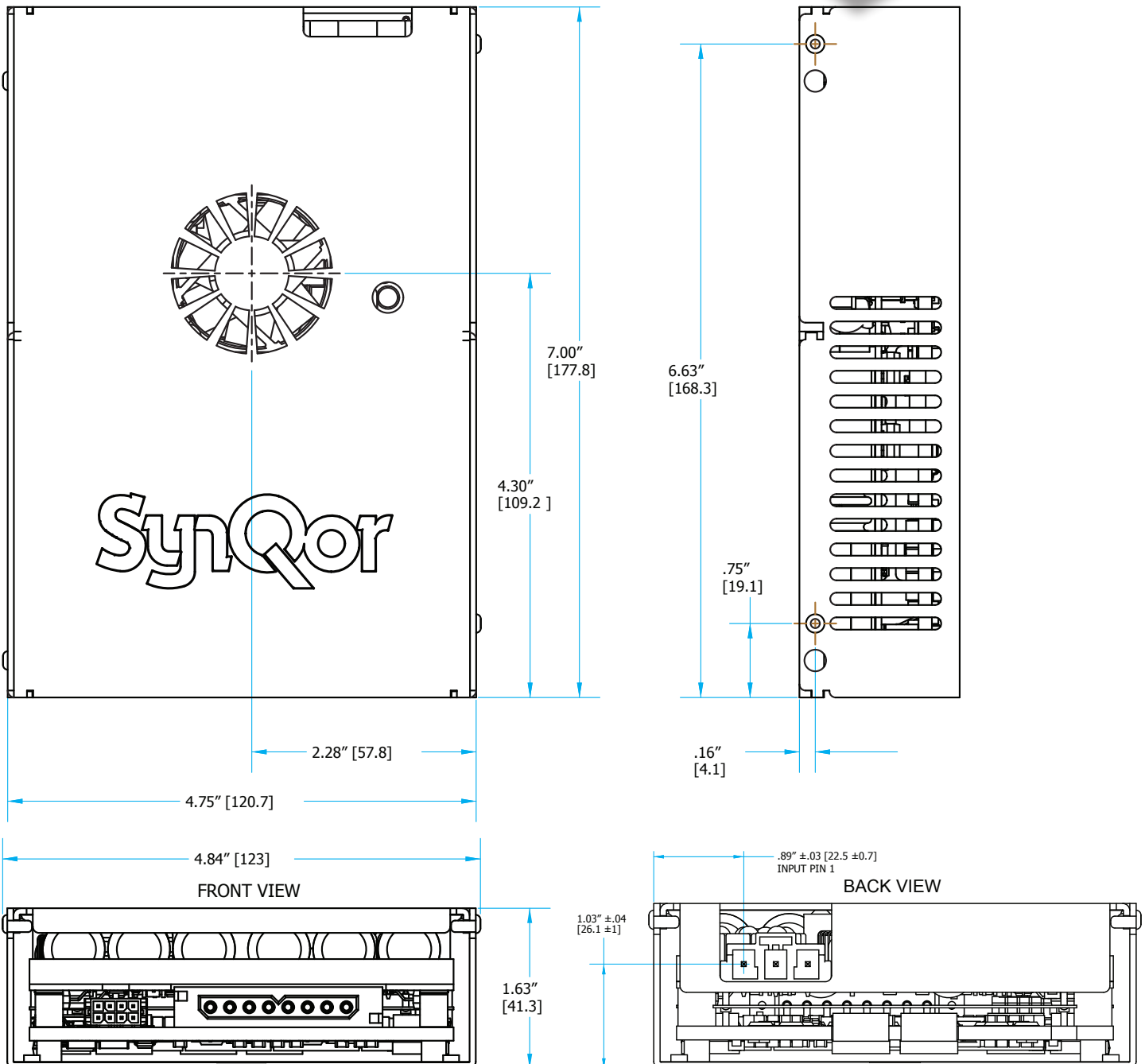



Medical Grade DC-DC Converters Rated for CF Patient Contact and Defibrillation Proof

Product Features

GENERAL SPECIFICATIONS

- High Efficiency, up to 93% at full rated load current
- Industrial standard quarter-brick pin-out configuration
- Low leakage; EN60601-1 compliant

SAFETY

- Reinforced Insulation
- UL 60601-1:2003
- Can/CSA-C22.2 No. 60601-1-08
- Can/CSA-C22.2 No. 60601-1-M90
- EN 60601-1:2006
- EN 60601-1/A2:1995
- IEC 60601-1:2005
- IEC 60601-1/A2:1995
- ANSI/AAMI ES60601-1:2005
- EN55011, 55022 and 61000
- CF Patient Contact
- Defibrillation Proof

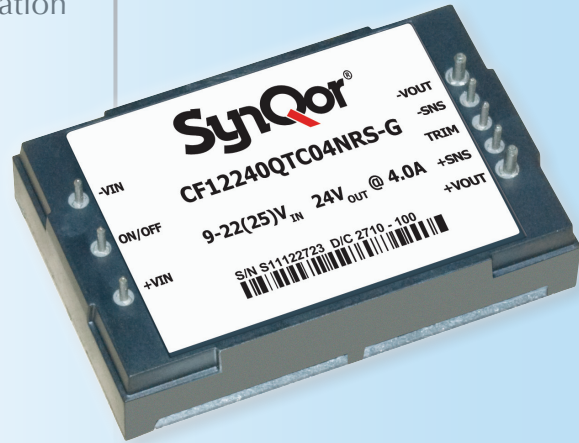

*Defibrillator proof
Type CF equipment*

		Output Voltage			
CFQor	Series	5V	12V	15V	24V
12Vdc Nominal Input (9-22V Continuous Input Range; 9-25V transient)					
Quarter Brick	CF12	20A 100W	8A 96W	7A 105W	4A 96W
24Vdc Nominal Input (18-36V Continuous Input Range; 18-50V transient)					
Quarter Brick	CF24	24A 120W	10A 120W	8A 120W	5A 120W
48Vdc Nominal Input (34-75V Continuous Input Range; 34-100V transient)					
Quarter Brick	CF48	25A 125W	12A 144W	10A 150W	6A 144W



P A C K A G E S

The CFQor series of Quarter-Brick DC-DC converters is designed for medical applications that require isolation and leakage current levels that comply with IEC60601-1 for CF patient contact & are also defibrillation proof.

They are high efficiency, fixed switching frequency converters based on SynQor's well proven and reliable industrial grade products. CFQor products are fully encased for additional environmental protection.

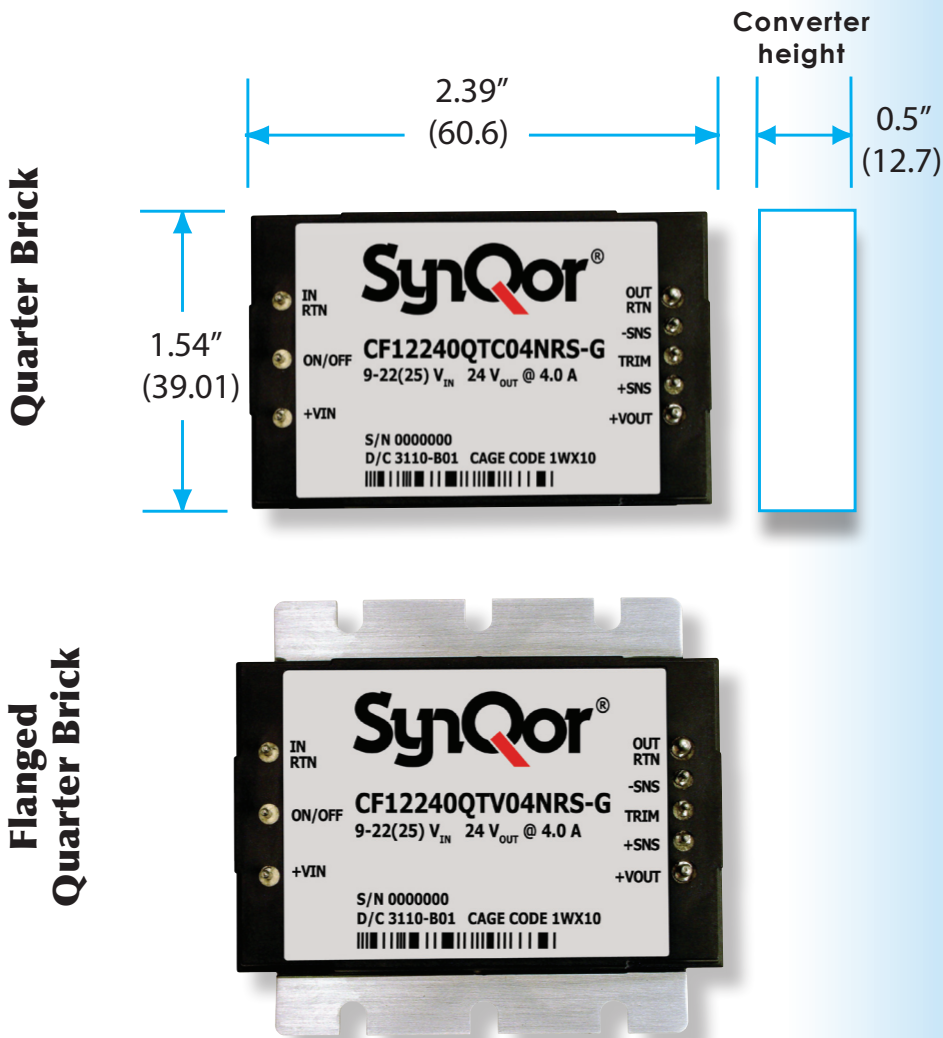

Defibrillator proof
Type CF equipment

SynQor® *Advancing The Power Curve®*

Founded in 1997, SynQor® quickly became the technology, quality and service leader for high efficiency dc-dc converters for the telecom/datacom marketplace. The PowerQor®, BusQor®, DualQor®, iQor™, and NiQor® product lines, combined with SynQor's unmatched lead-times, flexibility, design support and lowest total cost of ownership are the benchmark sought by SynQor's worldwide customers.

In 2004, SynQor began its successful entry into the industrial, railway, medical and military market segments with the InQor®, RailQor®, ACuQor®, MilQor® and UPS product lines. These new technology leading dc-dc and ac-dc product lines have enabled customers to realize vast savings in space, weight and overall system costs while dramatically increasing power densities and end-system performance. Equally important is the service and support advantage SynQor has brought to customers in these market segments.

SynQor is a privately owned U.S. company headquartered in Boxborough, Massachusetts, which is also the location of all of its manufacturing operations. SynQor has a design center in Dallas, Texas, and sales/marketing offices throughout the USA, Europe, Malaysia, Korea and China. More information is available on the company's website at www.synqor.com.



SynQor Headquarters

155 Swanson Road Boxborough, MA 01719-1316

Phone: 978-849-0600 Fax: 978-849-0602

Toll Free (USA): 888-567-9596

E-mail: mqnbfae@synqor.com

www.SynQor.com

